

XY2-100 cRIO Module

The custom module RX-XY2.100 give to customers the capabilities to control different kind of peripherals using the XY2-100 Standard.

Simply connecting the device on the standard XY2-100 connector placed on the module, you can use the power of the cRIO to implement fast PID loops, and custom control strategies driving directly the XY2-100 device.

As visible in the “Output Connector Figure”, each module is capable to generate the Clock Signal, the Sync Signal and a maximum number of three Data Lines (for example, with a module is possible to drive completely a three axis scanner), and it’s capable to read the “Status Signal” (not always present in the controlled devices).

The user can set different clock speed (from 0,1MHz to 1MHz) and can configure the number of data lines that can be used (see the figure Below).

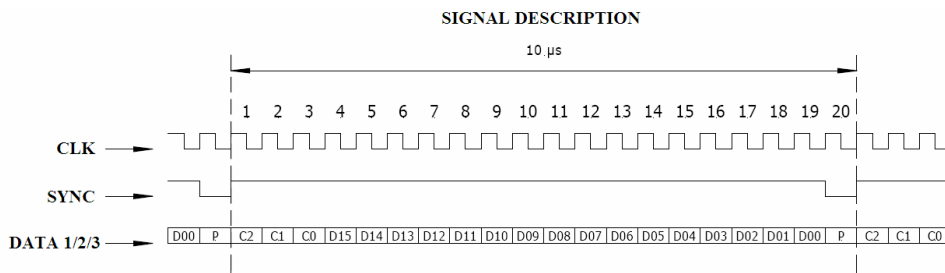
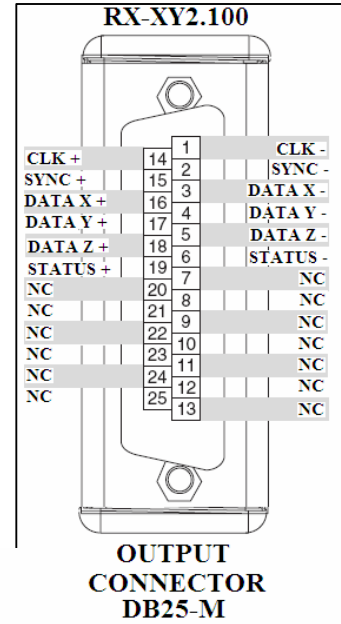

The module is shipped with the software driver that give to user the capabilities to independently send the datas in the Int-16 format on each data line, configuring the clock rate and the used data lines.

HARDWARE SPECS :

- Operating Temperature : -40...+70 °C
- Operating Voltage : 9-35V
- Operating current: 100mA @ 24V (max)
- Differential Voltage Out : 3.1V (typ)
- Current out : \pm 100mA/ch (max)
- Differential rise/fall time : 6ns (typ)

